

# Building Compassion

julia ferraioli  
Open source @ Google  
@juliaferraioli

# **Transcript:**

**[bit.ly/building-compassion](https://bit.ly/building-compassion)**

**Content warnings: chronic illness, medical trauma, psychological trauma**

# A bit about me

- Lots of different jobs in tech
- Lived lots of different places
- Open source citizen
- (Don't) ask me about licenses



A "survival card" multi-tool



**Me, smiling crouched over inside the international spy museum**

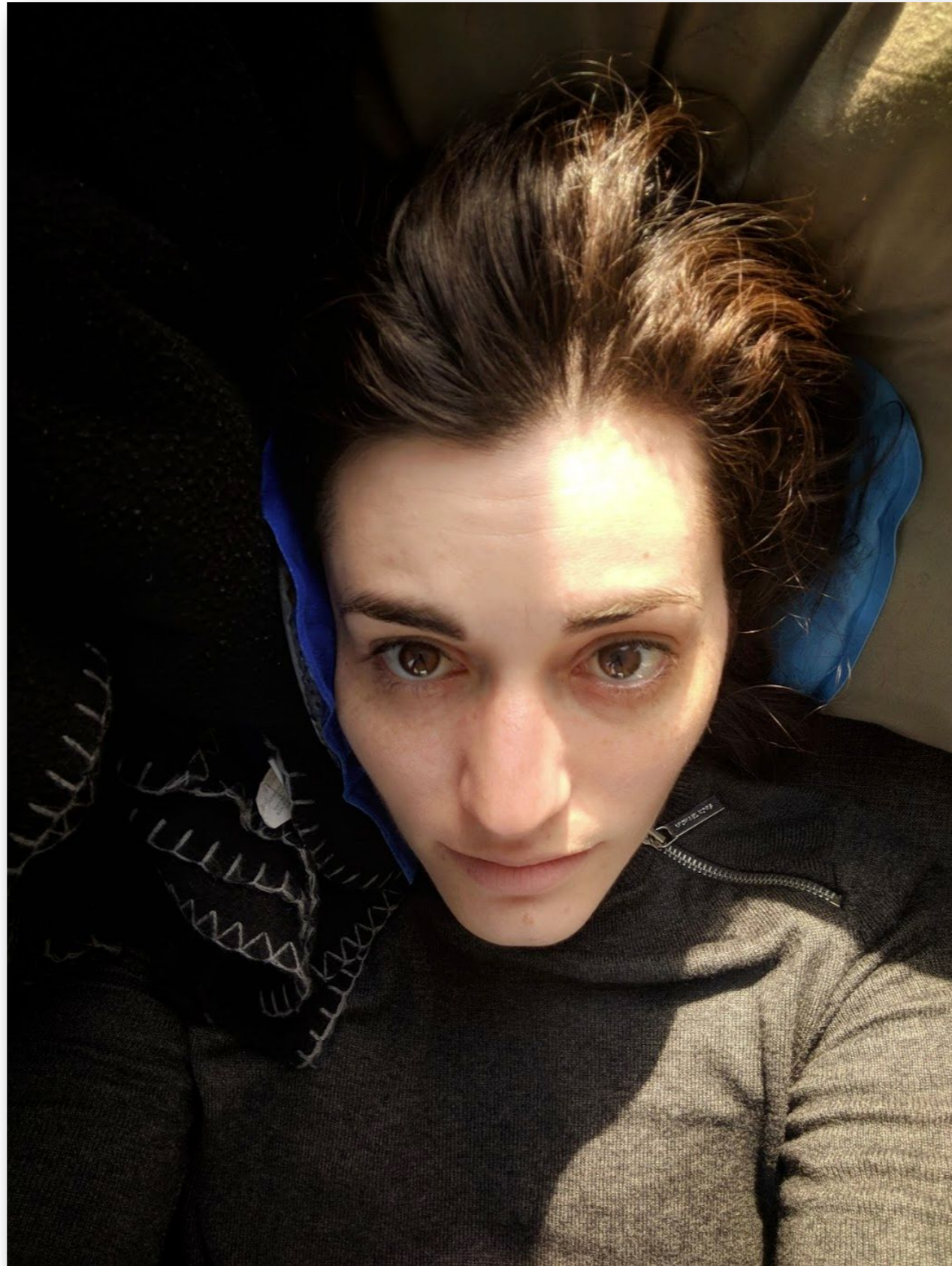

**Me lying on the couch with an ice pack positioned behind my head**

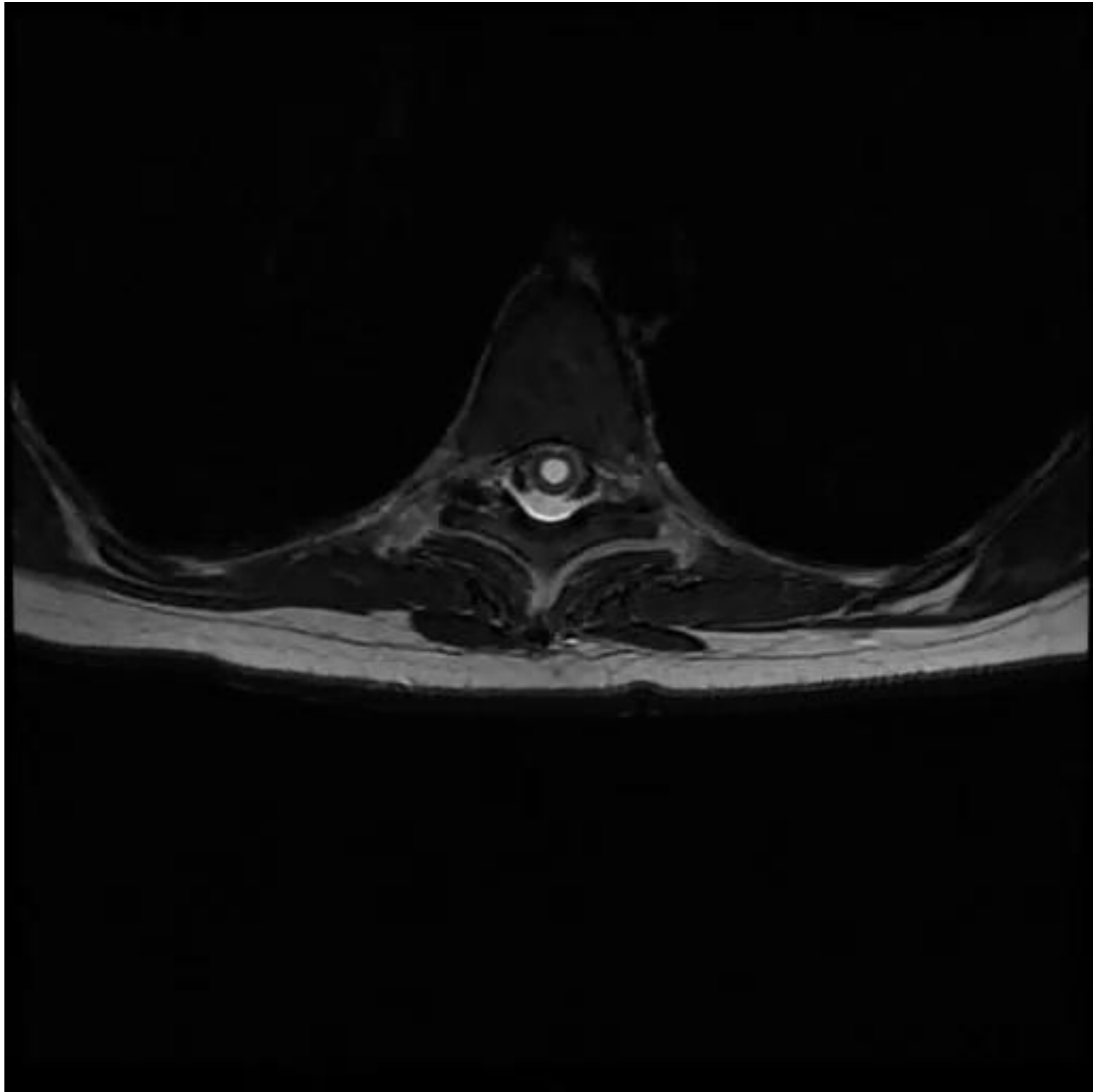

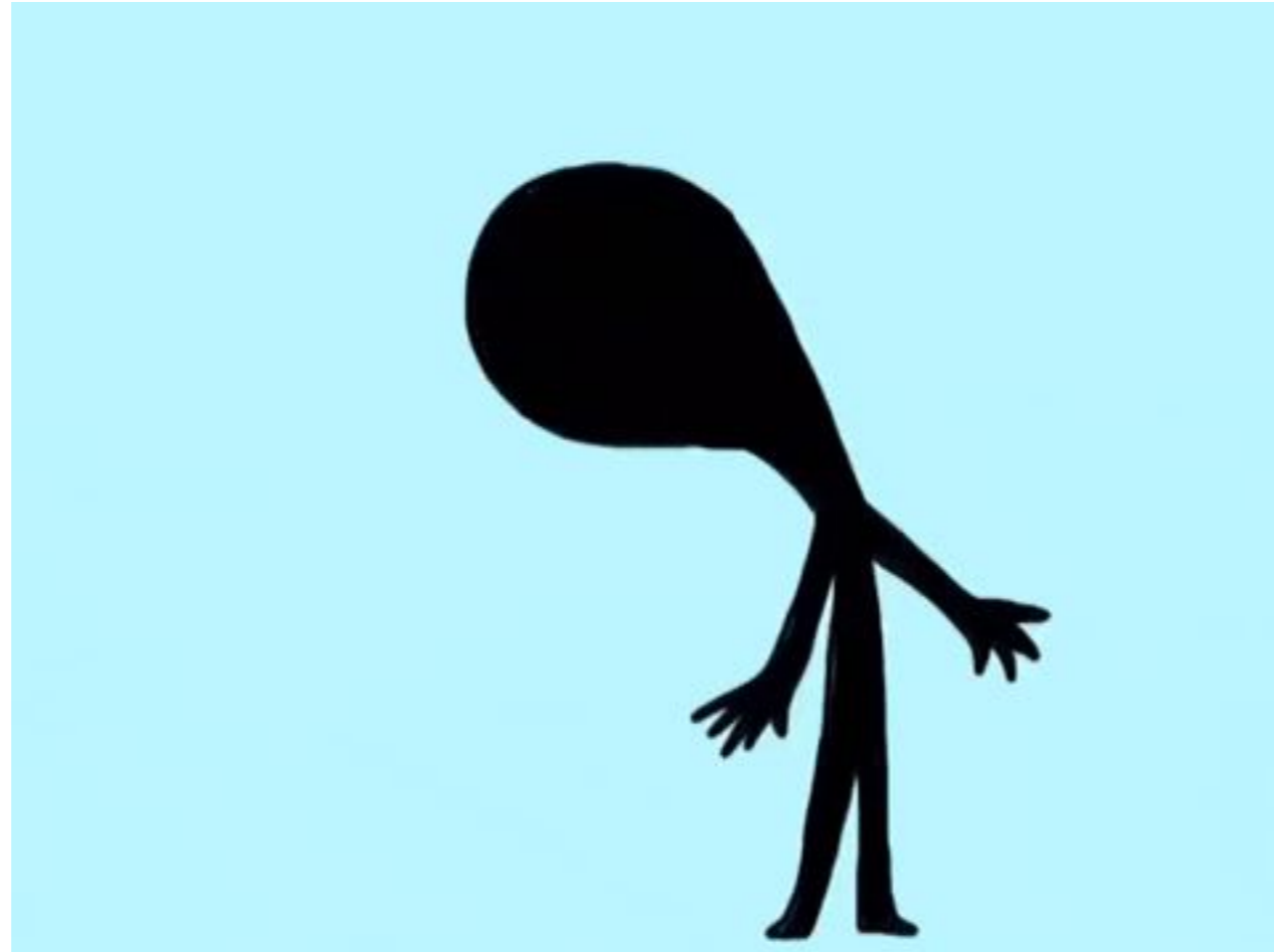

**GIF of a cartoon person breaking into pieces and falling apart**



# A sampling of surgery

- Chiari decompression
- Laminectomy
- Syringosubarachnoid stent
- Trans ethmoid repair
- RISA cisternogram
- Intracranial pressure monitoring



CC-BY Photo of a keyboard as the return button is struck by elenchos:  
<https://flic.kr/p/yJsPi>



**E\_TOO\_MUCH\_EMAIL\_RIP\_ALSO\_LOL**



CC-NC Photo of graffiti with the words "Pain has a face" by Duncan c:  
<https://flic.kr/p/7sHskh>

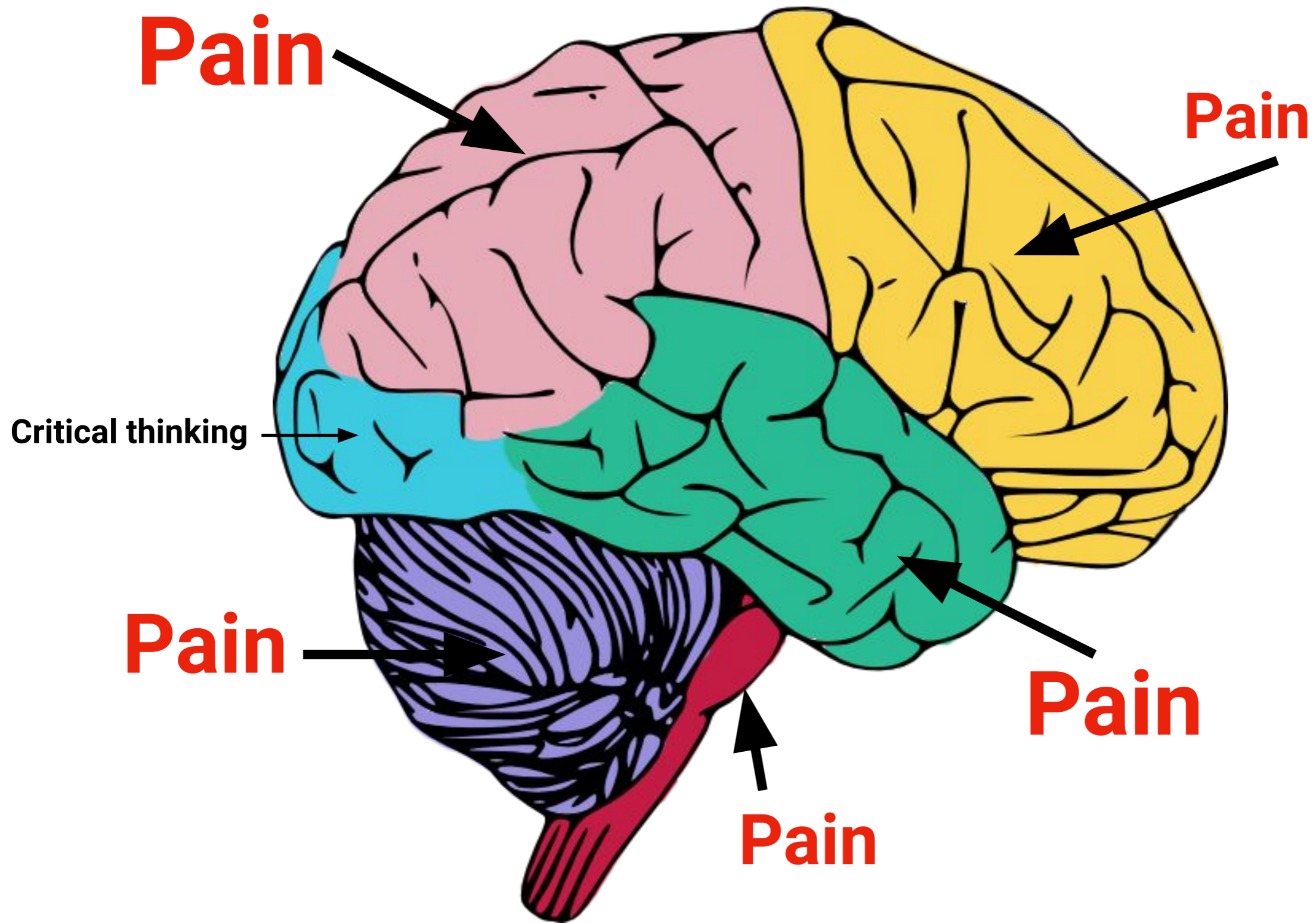

**A totally fake diagram of the brain and its functions**



**CC-NC-ND photo of a woman with her hand in front of her face by Felipe Benavente:  
<https://flic.kr/p/Wf5oGx>**

**“Can I be in pain and it be okay?”**

*–Everyone with chronic pain*

# Other challenges

- No freezers for ice packs
- Needing to lay down
- Lack of energy
- Doors
- Judgement from others

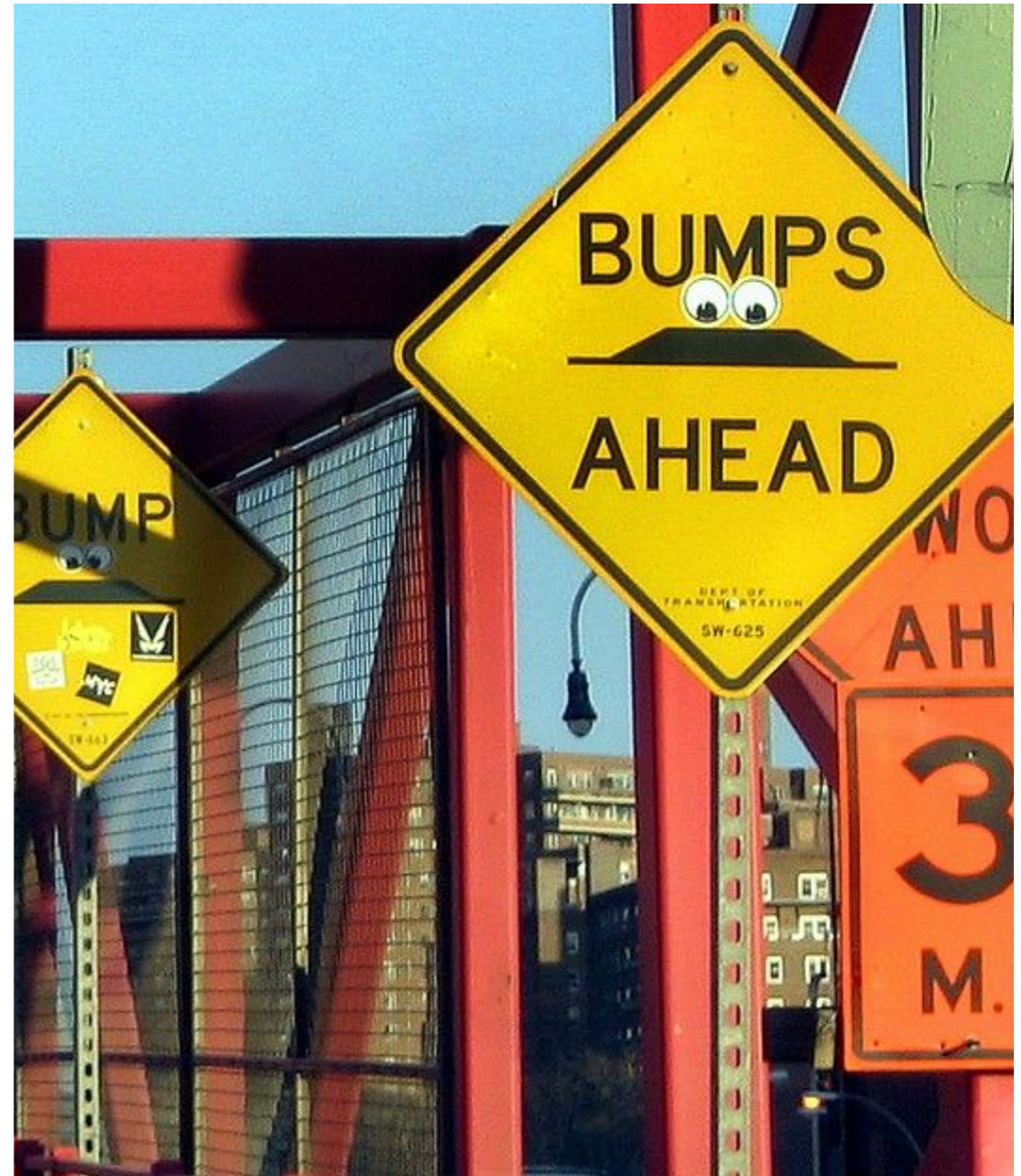

CC-BY photo of bumps ahead sign with fake eyes by eva101:

<https://flip.kr/p/E8221>



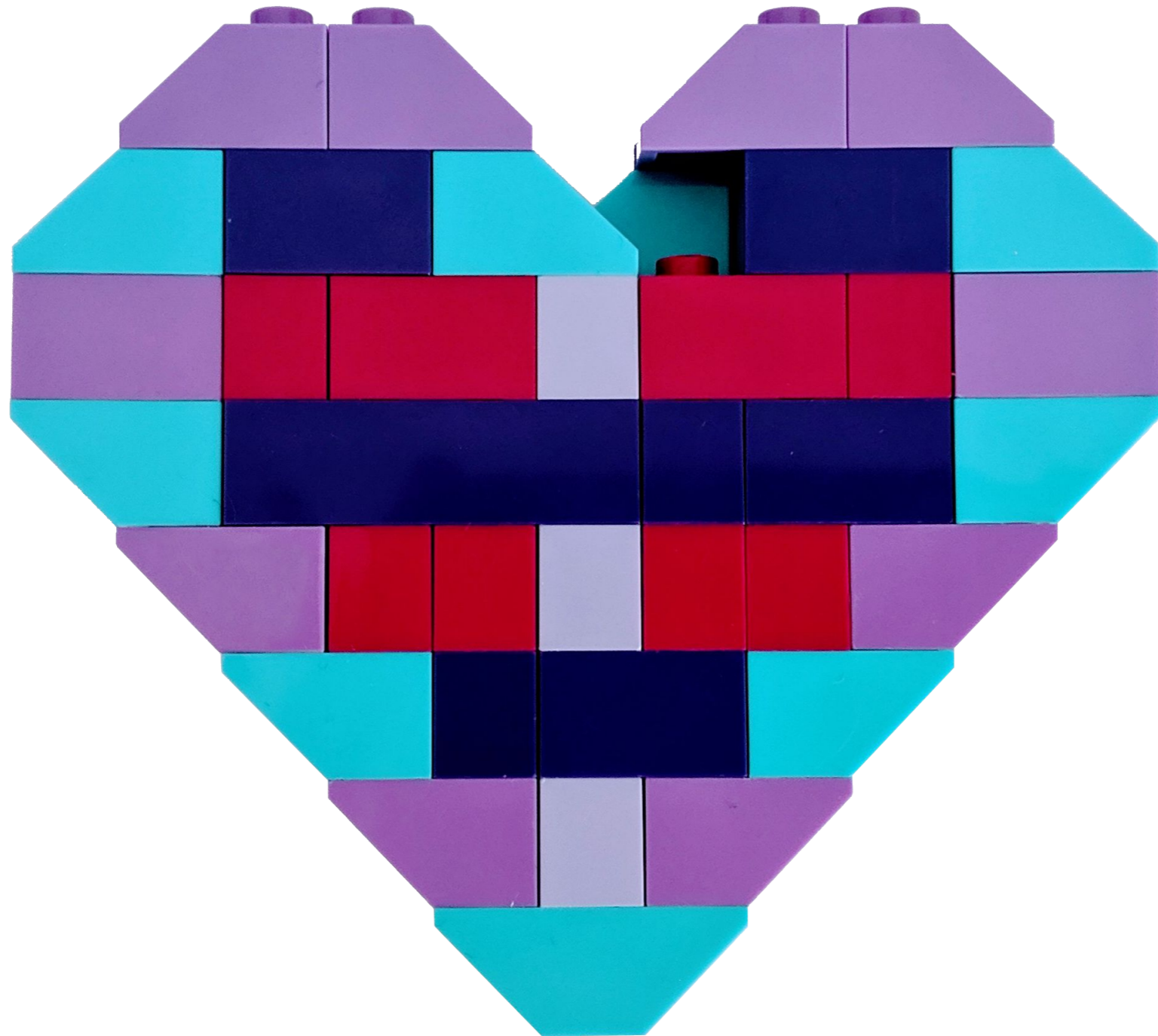

**Let's build compassion**

# Self compassion

- This is HARD
- We all deserve to not constantly put ourselves down
- Even HARDER when living with pain
- Get by with a little help from your friends

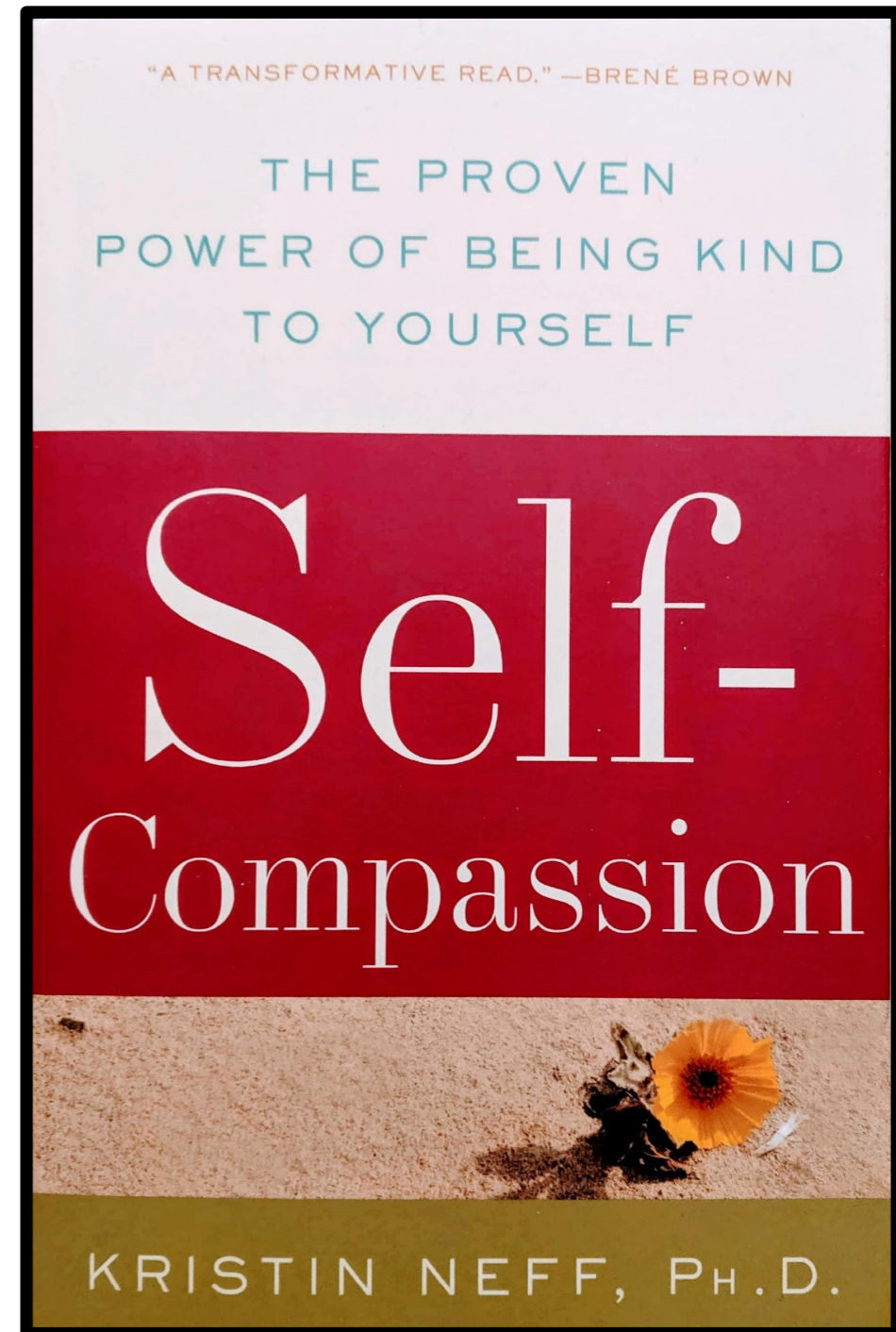

Photo of the cover of **Self-Compassion**, by **Kristin Neff, Ph.D.**

# Workplace compassion

- Colleagues are people too!
- Open the door for trust
- Reset your defaults
- Behavior is not code
- Make a B game day okay

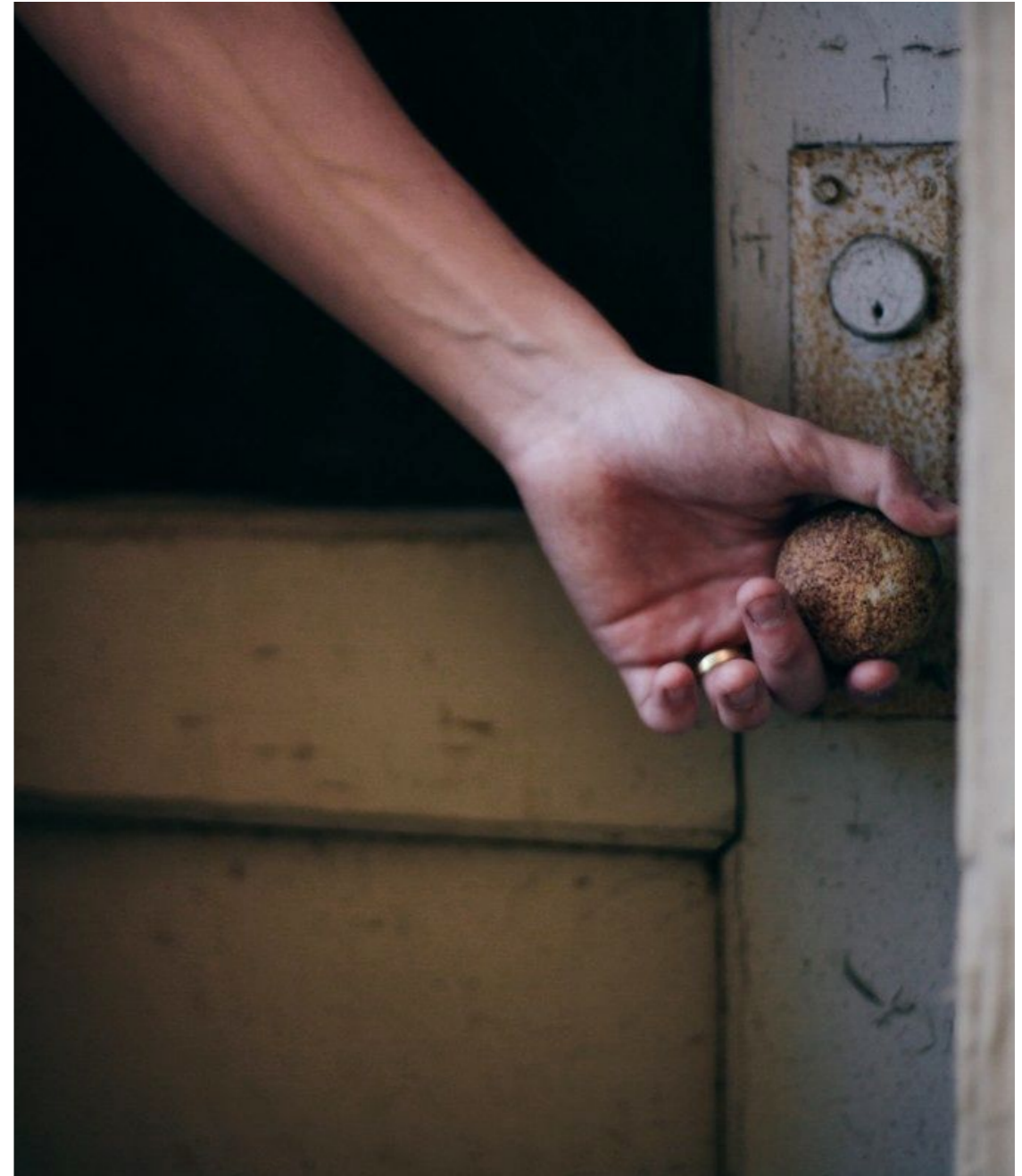

Photo of a hand about to open a door

**“I want it to be okay that I’m in pain.”**

*–Everyone with chronic pain*

# Workplace compassion



CC-NC-ND photo of “communication” written on a sidewalk by shakakahnevan:

@juliaferraioli

<https://flic.kr/p/bmaRUa>



**Save the hot takes for Twitter**



**Save the hot takes for Twitter  
or > /dev/null**



# Compassionate products

- Consider your defaults
- Optimize for harm minimization
- Products themselves can be built for compassion



CC-NC Photo of Braille Lego by Mike Gifford: <https://flic.kr/p/rvE4aZ>





**Photo of a shoehorn**



Photo of sliced fruit, by silviarita:  
<https://pixabay.com/images/id-2665240/>



**Product photo of Lex, the wearable chair: [lexbyastride.com](http://lexbyastride.com)**

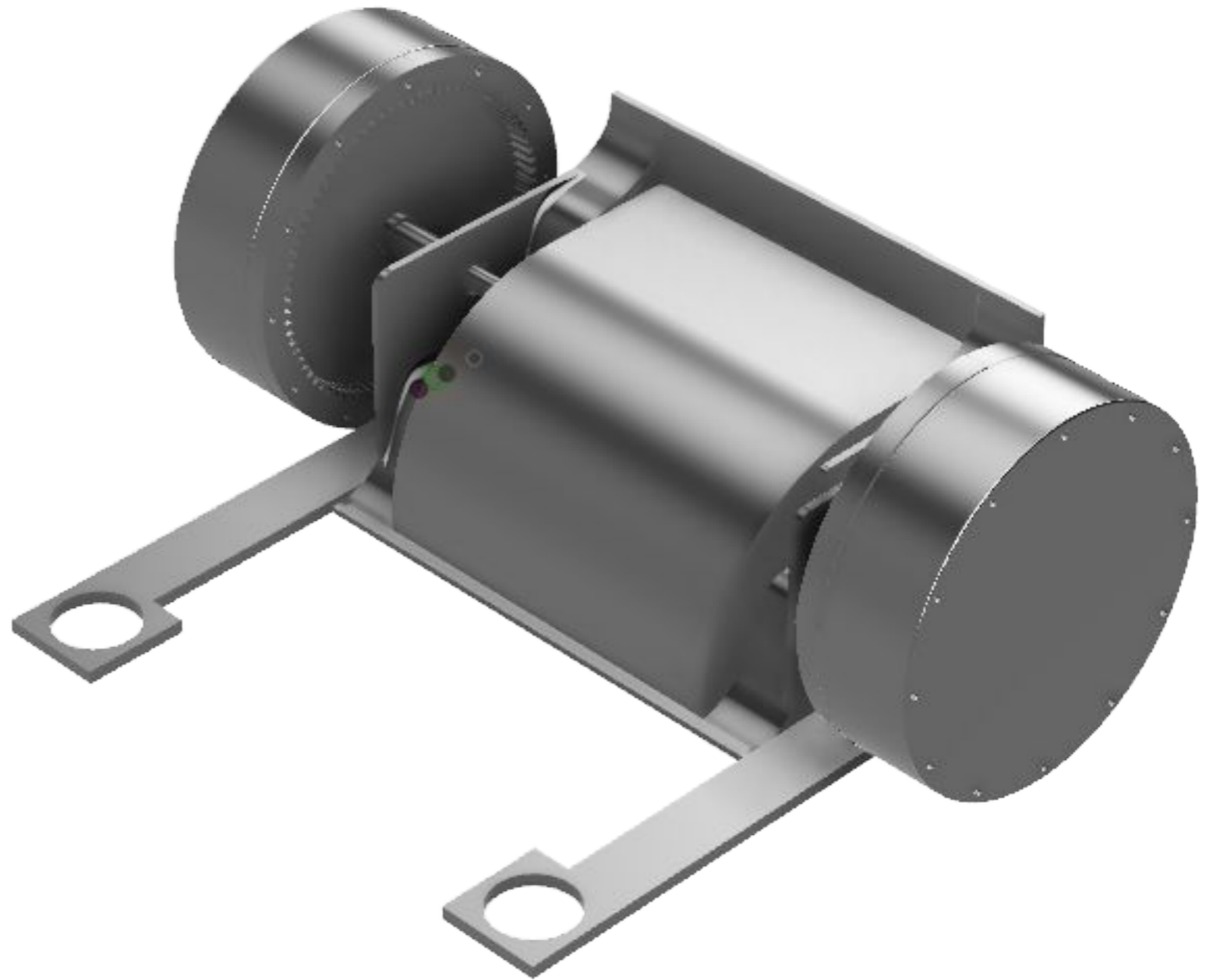

**Product render of the SmartCan: [smartcan.app](https://smartcan.app)**

**“I want to spend less time on things that cause me  
*more pain.*”**

*–Everyone with chronic pain*

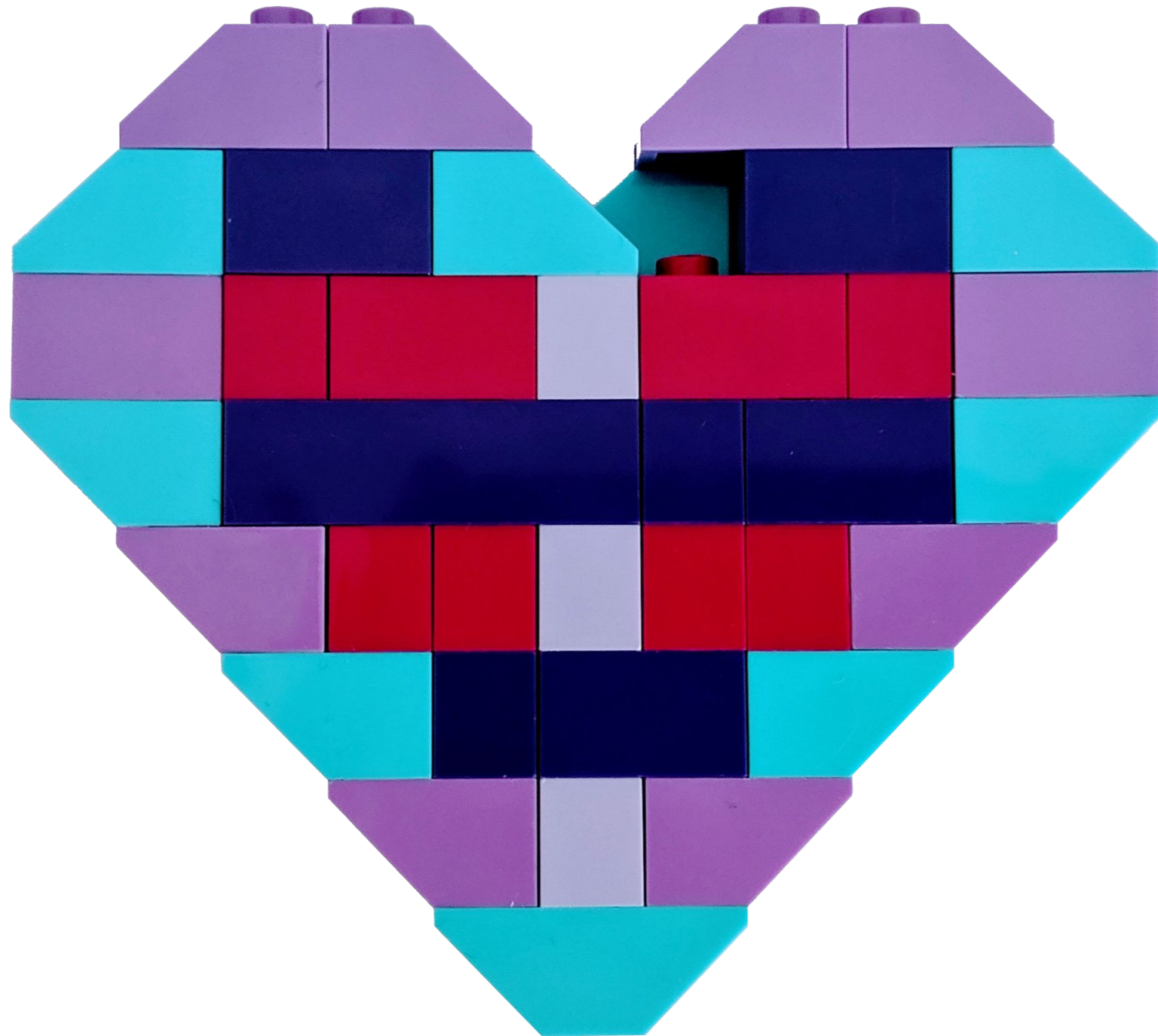

**We can build compassion**

# Thank you!

@juliaferraioli

me@juliaferraioli.com

